

PRORIL

50 Hz

X-SMART Series, all components in contact with liquid of the stainless steel dewatering pumps are made of 304 stainless steel. These pumps are designed for handling clean water or screened wastewater. With the use of the food-graded lubricant, they are also applicable to the aquaculture industry.

Stainless Steel Pump

X-SMART 215

Dewatering Pump



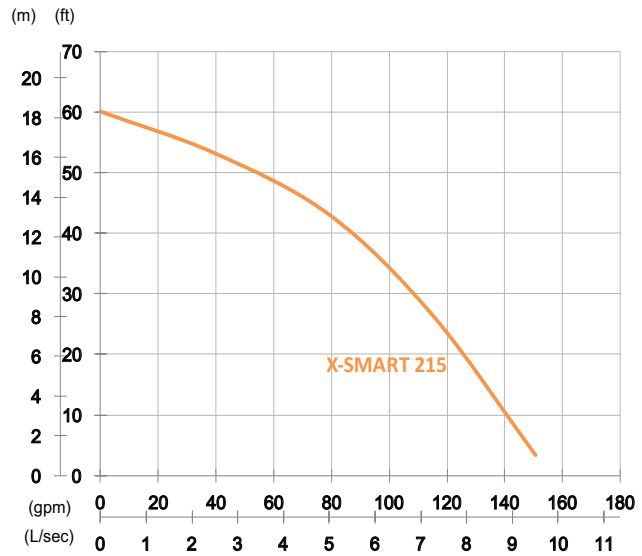

Shaft Speed : 2850 rpm

Outlet : 50mm, 2in

OUTPUT	HEAD	FLOW
1.5 kW	Rated : 13.1m, 43ft	Rated : 5 L/s, 79 gpm
2 HP	Max : 18.3m, 60ft	Max : 9.5 L/s, 150 gpm

Solid Passage : 7 mm, 0.3 in

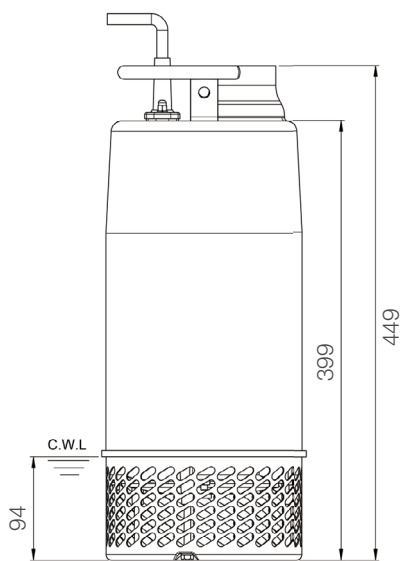
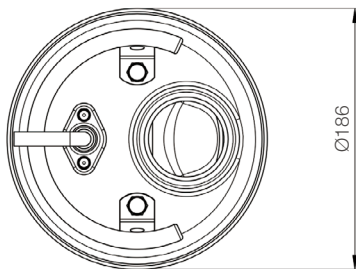

unit : mm

Weight : 19kg / 42 lbs

Pump Type		Electric Submersible Pumps
		1-Phase, 3-Phase
Motor	Type	Induction Motor
	Poles	2 Pole
	Insulation	Class F
	Protector	Circle Thermal Protector
	Starter	1-Phase · Capacitor-Run, 3-Phase · D.O.L.
Lubricant		Food Grade (ISO VG32)
Impeller Type		Closed
Shaft Seal		Double Mechanical Seal
		Silicon Carbide VS Ceramic / Carbon
Bearings		C3 Shielded ball bearings
Cable		PVC (CSA Certified) / H07RN-F
		10m (33ft) or longer upon request.
Materials	Pump Casing	Stainless Steel
	Impeller	Stainless Steel
	Motor Frame	Stainless Steel
	Motor Shaft	Stainless Steel
	Strainer	Stainless Steel
Max. Liquid Temperature		40°C (104°F)
Max. Submersion Depth		20m (66ft)
pH Range		pH 5 - pH 8